

MultiCam® Register Marks

Functional Description:

The MultiCam® offers multiple lateral mark patterns to meet a range of printing needs. The camera can read four, six or eight colors across. The 0.039" (1 mm) and 0.020" (0,5 mm) marks are depicted on this page.

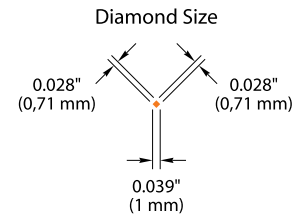

White Space Requirements
for 4-color Lateral Marks

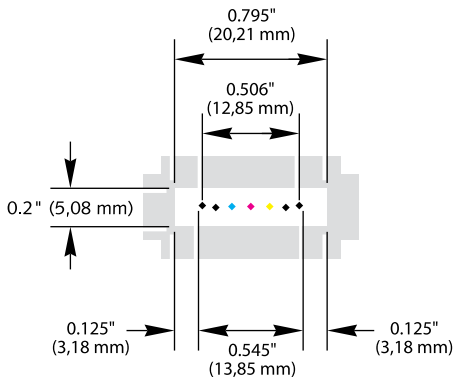

Up to 3,500 fpm (17,8 m/sec)

White Space Requirements
for 6-color Lateral Marks

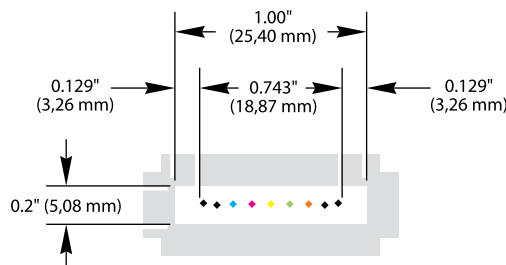

Up to 3,500 fpm (17,8 m/sec)

White Space Requirements
for 8-color Lateral Marks

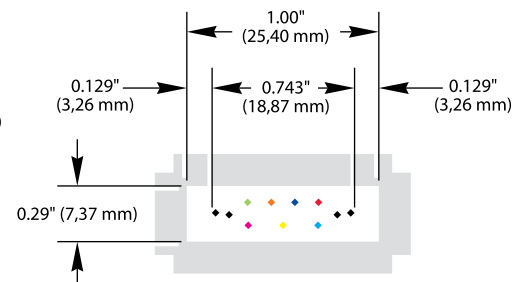

Up to 3,500 fpm (17,8 m/sec)

Diamond Size

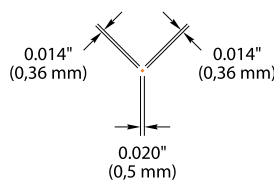

White Space Requirements
for 4-color Lateral Marks

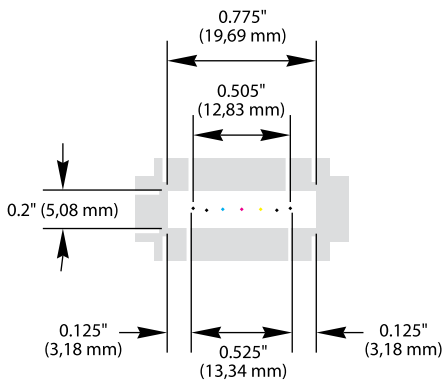

Up to 3,500 fpm (17,8 m/sec)

White Space Requirements
for 6-color Lateral Marks

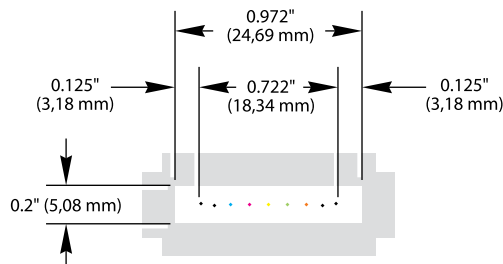

Up to 3,500 fpm (17,8 m/sec)

White Space Requirements
for 8-color Lateral Marks

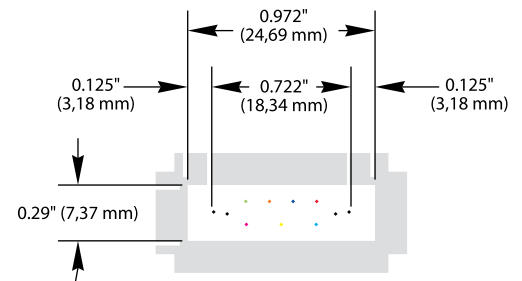

Up to 3,500 fpm (17,8 m/sec)

Functional Description:

The MultiCam® offers many circumferential mark patterns to meet a range of printing needs. The camera can read four, six or eight colors ahead. The 0.039" (1 mm) mark, Autotron™ mark and RCS 4000 mark are depicted on these pages.

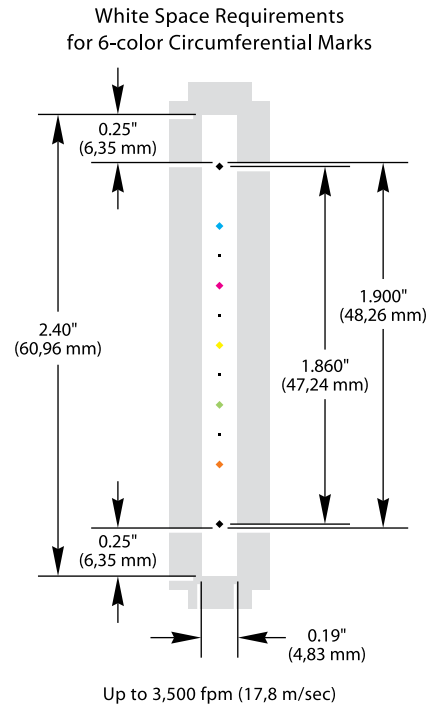
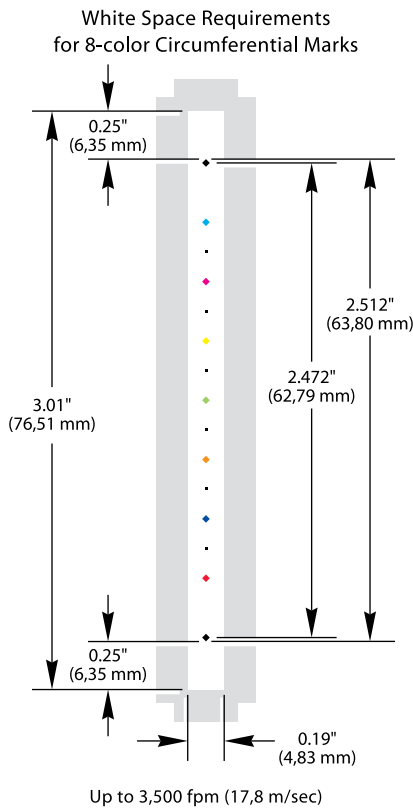
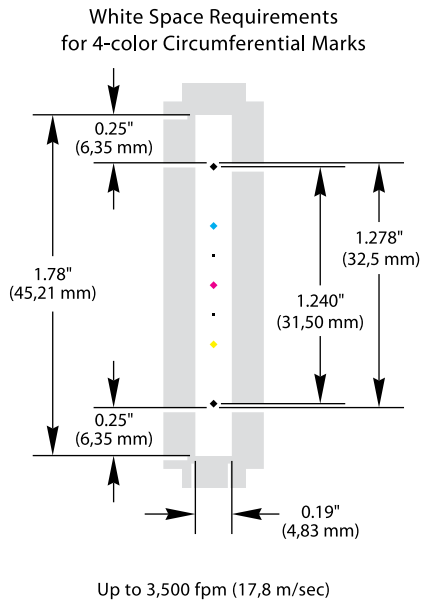
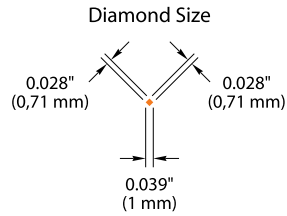

RCS 4000 Mark Dimensions

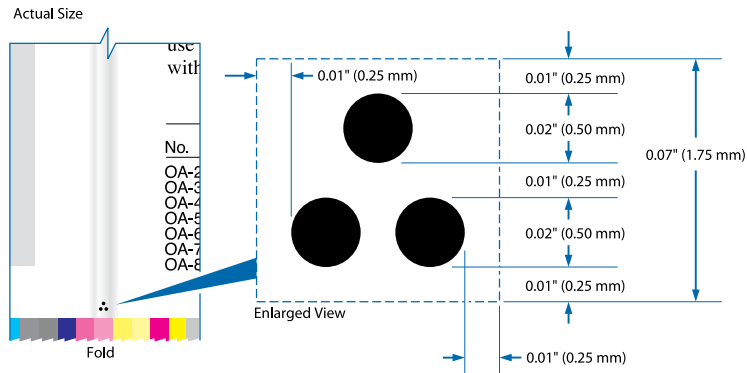

White Space Requirements for 4-color Autotron™ Marks

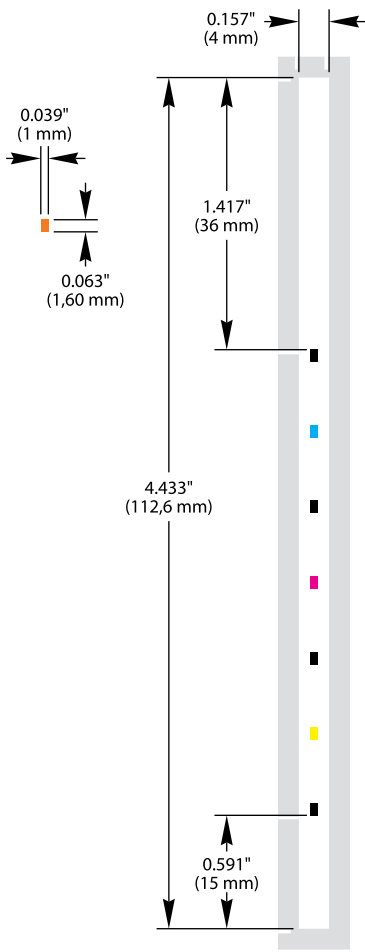

Up to 3,500 fpm (17,8 m/sec)

Also available Autotron™ 5 & 6 color patterns.

Diamond Size

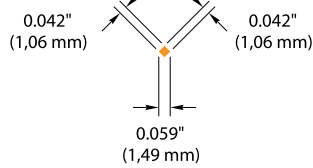

White Space Requirements for 6-color Circumferential Marks

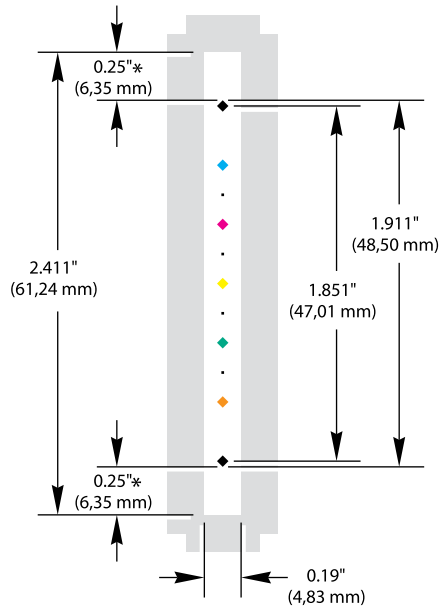

Up to 3,500 fpm (17,8 m/sec)

White Space Requirements for 8-color Circumferential Marks

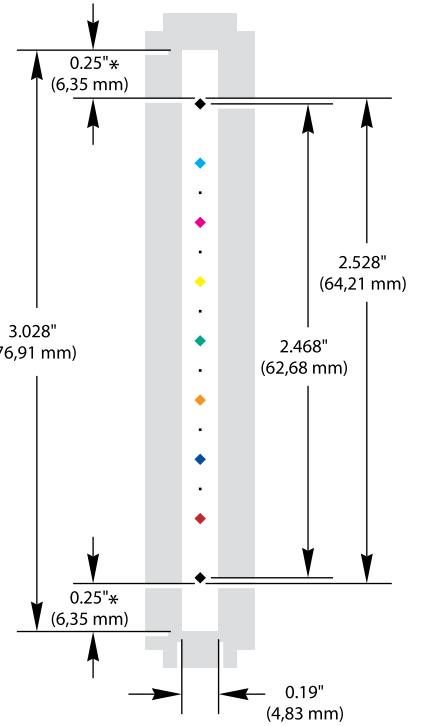

Up to 3,500 fpm (17,8 m/sec)

Specifications subject to change without notice

* 0.5" (12,7 mm) is required when running this pattern with RGS IV.



The Americas

United States

+1 414 566 7500 **TEL**

sales@quadtechworld.com

Asia-Pacific

Singapore

+65 6538 3517 **TEL**

apsales@quadtechworld.com

China

+86 21 62882525 **TEL**

chinasales@quadtechworld.com

India

+91 79 2642 1863 **TEL**

indiasales@quadtechworld.com

Tokyo, Japan

+81 48 839 8831 **TEL**

tokyosales@quadtechworld.com

Osaka, Japan

+81 6 6330 0919 **TEL**

osakasales@quadtechworld.com

Europe

France • Germany • Italy • Ireland •

The Netherlands • United Kingdom

+31 294 496222 **TEL**

qtesales@quadtechworld.com